

SMK Bluetooth® Audio Module BT505A

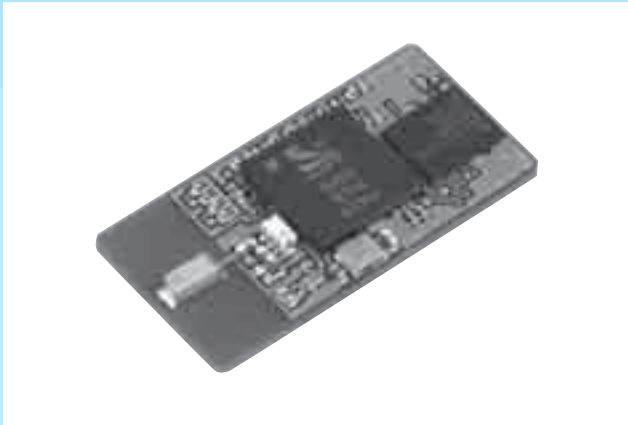

■ Outline

BT505A is a module that realizes both wireless reproduction of audio sound and hands-free talks.

■ Features

- Receives audio signal from a cellular phone of a portable audio device and reproduces audio sound.
- Supports SCMS-T for copyright preservation and can receive sound from a cellular phone with 1-Segment functions.
- Supports HSP/HFP and enables hands-free talks toward the call received by a cellular phone.

■ Specification

| | |
|-----------------------------|--|
| Bluetooth Specification | Version 2.0+EDR |
| Power Class | Class2 |
| Support Profile | A2DP (Advanced Audio Distribution Profile) |
| | AVRCP (Audio/Video Remote Control Profile) |
| | HSP (Headset Profile) |
| | HFP (Hands-free Profile) |
| CODEC | SBC (Sub Band CODEC) |
| Audio Frequency Range | 100Hz to 15kHz |
| Power Supply | 2.8 to 3.6V DC |
| Operating Temperature Range | -20°C to +80°C |
| Dimension | 26mm(W)×12.8mm(D)×2.5mm(H) |

■ Application

Wireless speakers, portable stereo sets, stereo headsets, telephone conference systems

■ Block Diagram

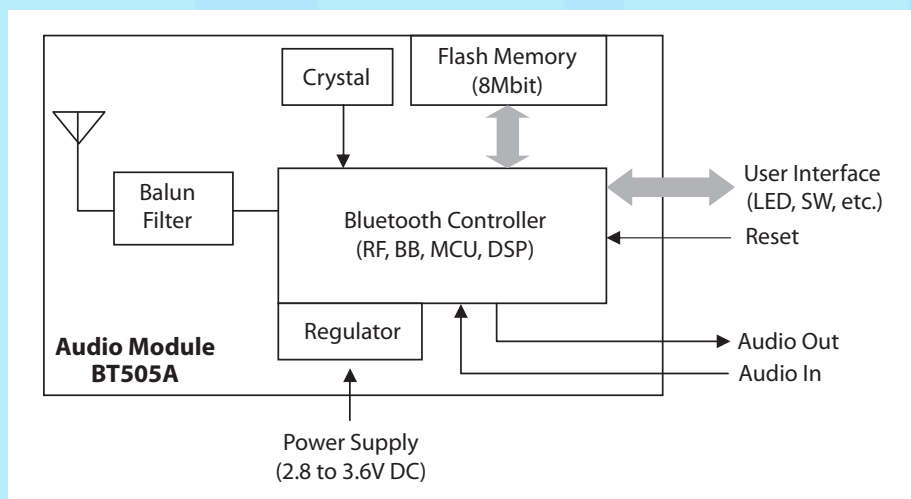

Bluetooth® as word mark or logo is a trademark owned by Bluetooth SIG, Inc. SMK is awarded permission to apply the trademark.

PICKUPNEWS

SMK CORPORATION <http://www.smk.co.jp/>
 No. 5-5, Togoshi 6-chome, Shinagawa-ku, Tokyo 142-8511, Japan
 Tel : +81-3-3785-1111 Fax : +81-3-3785-1122

Research & Development Center TEL(03)3785-1438
 FAX(03)3785-2804

⚠ Caution

- Specification is subject to change without prior notice for improving performance of the product and so on.
- Dimension and specification described herein are limited to major items. When applying the products, please confirm details the drawing and spec sheets which will be provided upon request.
- Every product carried here is compliant to RoHS* requirements. For detail, please refer to our sales representative.
- *RoHS Directive : An EU Directive for restriction of the use of certain hazardous substances in electrical and electronic equipment.

PRINTED IN JAPAN
 2009.10.1,500 ©